

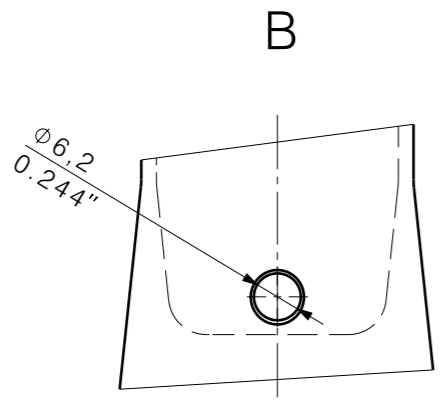

3.2 / (✓)

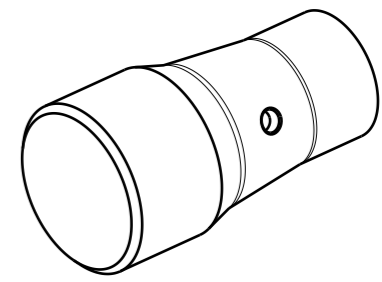
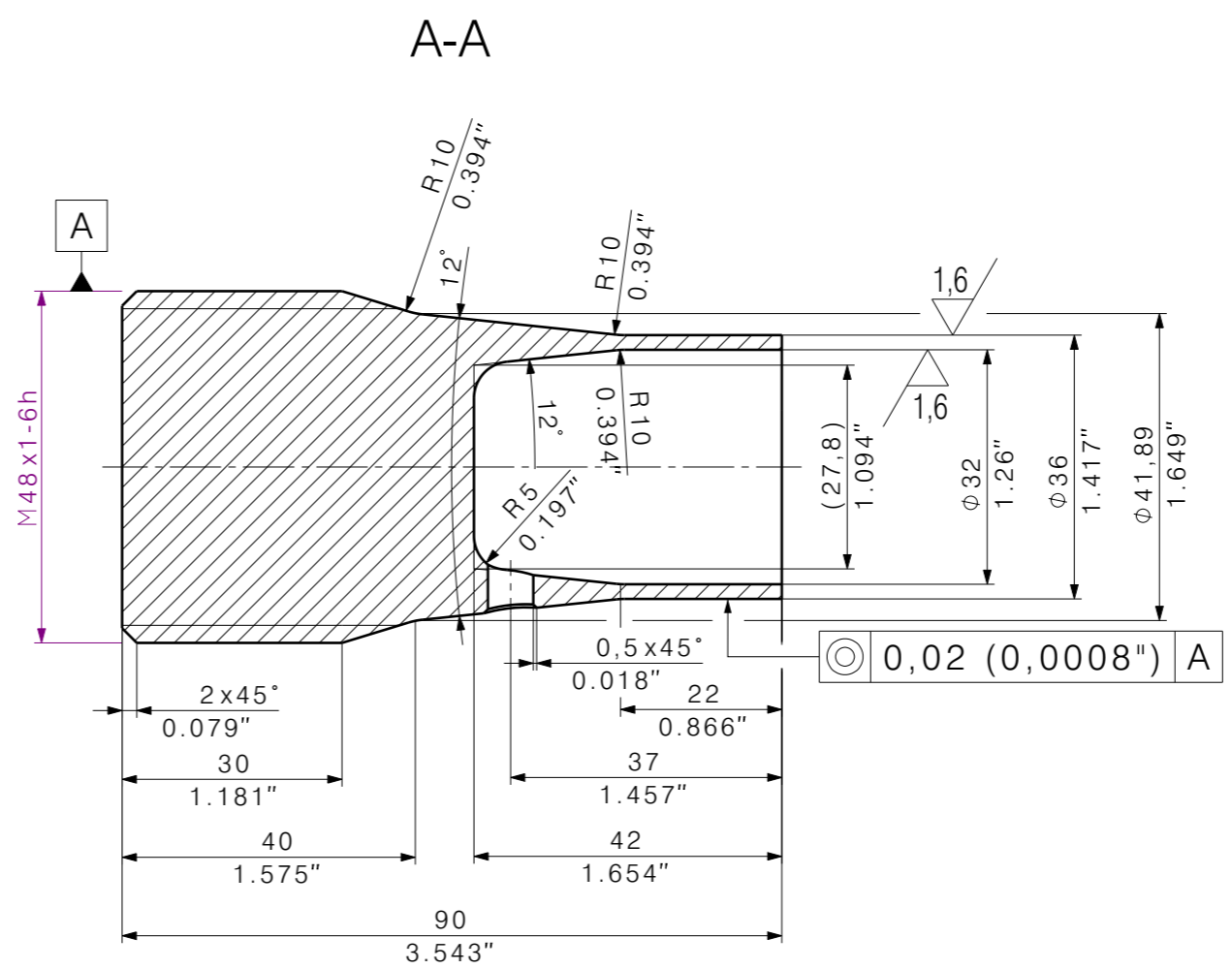
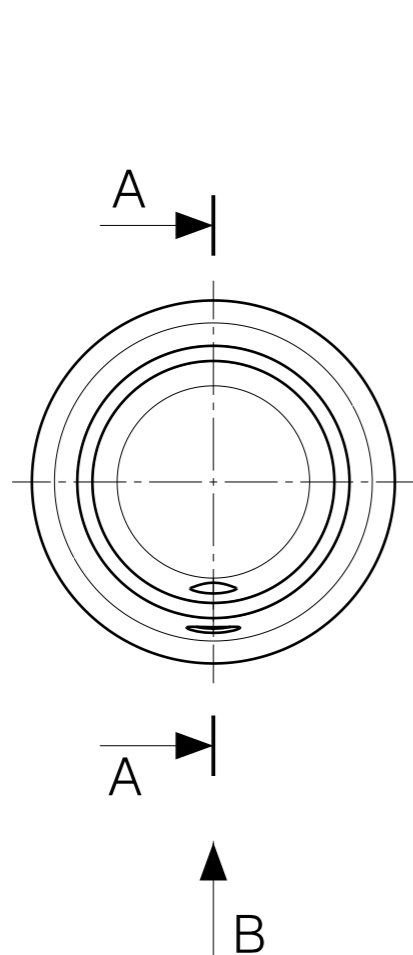

3. PROTECT THREAD FROM BLASTING
2. PERFORM SOLVENT CLEANING USING MEK
1. PERFORM #10 GLASS BEADED BLASTING

		Promitani: 							
		Delkove rozmery: mm							
		Netol. rozmery: ISO 2768-1-m							
Material: AISI 4130-N AMS-6348						0001			V.VANEK
Polotovar: ROUND BAR 2"				Index	Zmena	Od	Do	Datum	Podpis
Uprava povrchu: SEE NOTE 1				Model: CATIA V5		Typ: L410 NG		ATA: ---	
	Datum	Podpis		Meritko:		Nazev: TERMINAL			
Navrh:	23.07.15	V.VANEK		1:1					
Kontroloval:	22.10.15	T. RIPEL		3D hmota:		Cislo vykresu: VK11-202N		Index:	
Statika:	22.10.15	L. BEDRICH		0.7398 kg				-	
Unava:	22.10.15	J. PAPUGA		Kategorie:		List: 1			
Norm. ref.:	22.10.15	T. RIPEL		B					
Schvalil:	22.10.15	Z. ANCIK							

